

SUBMITTAL DATA

JOB/CUSTOMER:	SUBMITTED BY:
ENGINEER:	APPROVED BY:
CONTRACTOR:	ORDER NO:
SPECIFICATION REFERENCE:	

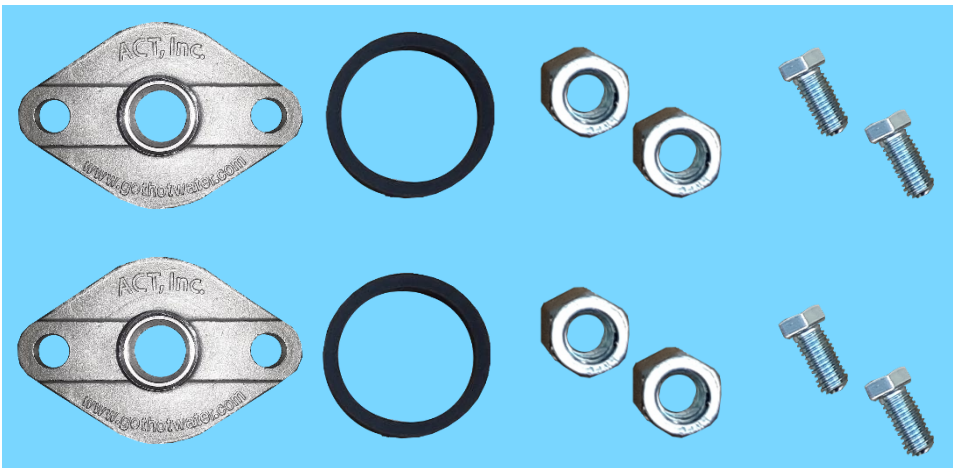

DESCRIPTION

This standard Flange Kit is used to install all the S3-100 and SS3-200 Systems.

The Flanges are composed of stainless steel and utilize a 3/4" MIP pipe thread on each side of the pump. The Flange Kit also complies with CA AB1953, no lead standards.

7/16" bolts/nuts are included to tighten the flange to the System along with a rubber gasket (included).

INCLUDES

The Original D'MAND KONTROLS® System Standard package comes with:

(2) Flanges

(4) Bolts
(4) Nuts

(2) Gaskets (Washers)

DIMENSIONS

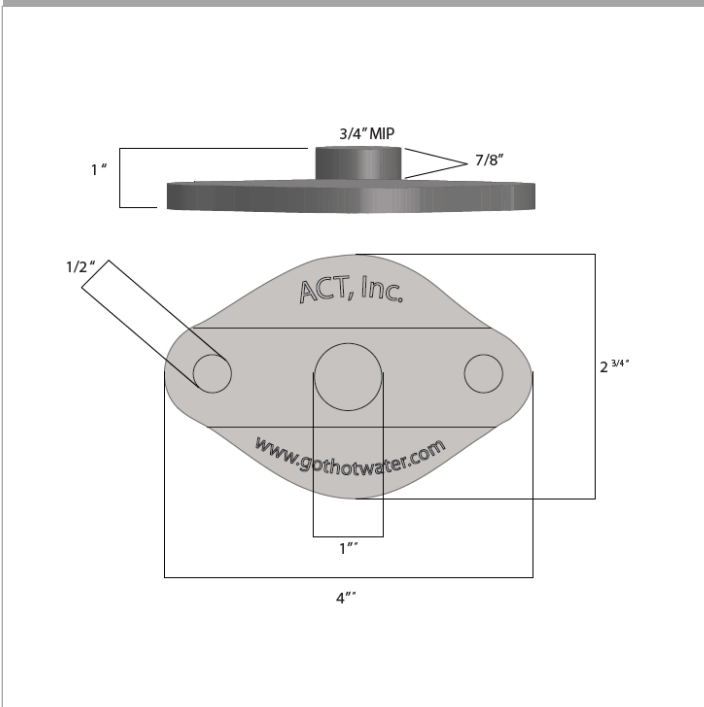

APPLICATIONS

Flanges are compatible with ACT Inc., D'MAND Kontrols® Systems: S3-100 and SS3-200.

NOT COMPATIBLE with ACT Inc., D'MAND Kontrols® Systems: ACT1 and C3-100.

These are for INDOOR USE ONLY and cannot be used in areas that may have direct exposure to water or extreme heat.

WARRANTY

Accessories: Hardwired Buttons, Wireless Transmitters and Receivers, all Hardwired or Wireless Motion Sensors and Receivers: Warranty (One Year from date of purchase) Labor is not included with Limited Warranty. In order to obtain services under this warranty, it is the responsibility of the purchaser to promptly notify the Company in writing and promptly deliver the item in question, delivery prepaid to the factory. The address for notification and delivery is ACT, Inc. D'MAND KONTROL® Systems, 3176 Pullman Street, Suite 119, Costa Mesa CA 92626. If the product or part in question contains no defects as covered in the warranty, the purchaser will be notified and billed for parts and labor charges in effect at the time of the factory examination and repair.